

(No Model.)

3 Sheets—Sheet 1.

# G. F. BALLOU. GRADUATING MACHINE.

No. 359,378.

Patented Mar. 15, 1887.

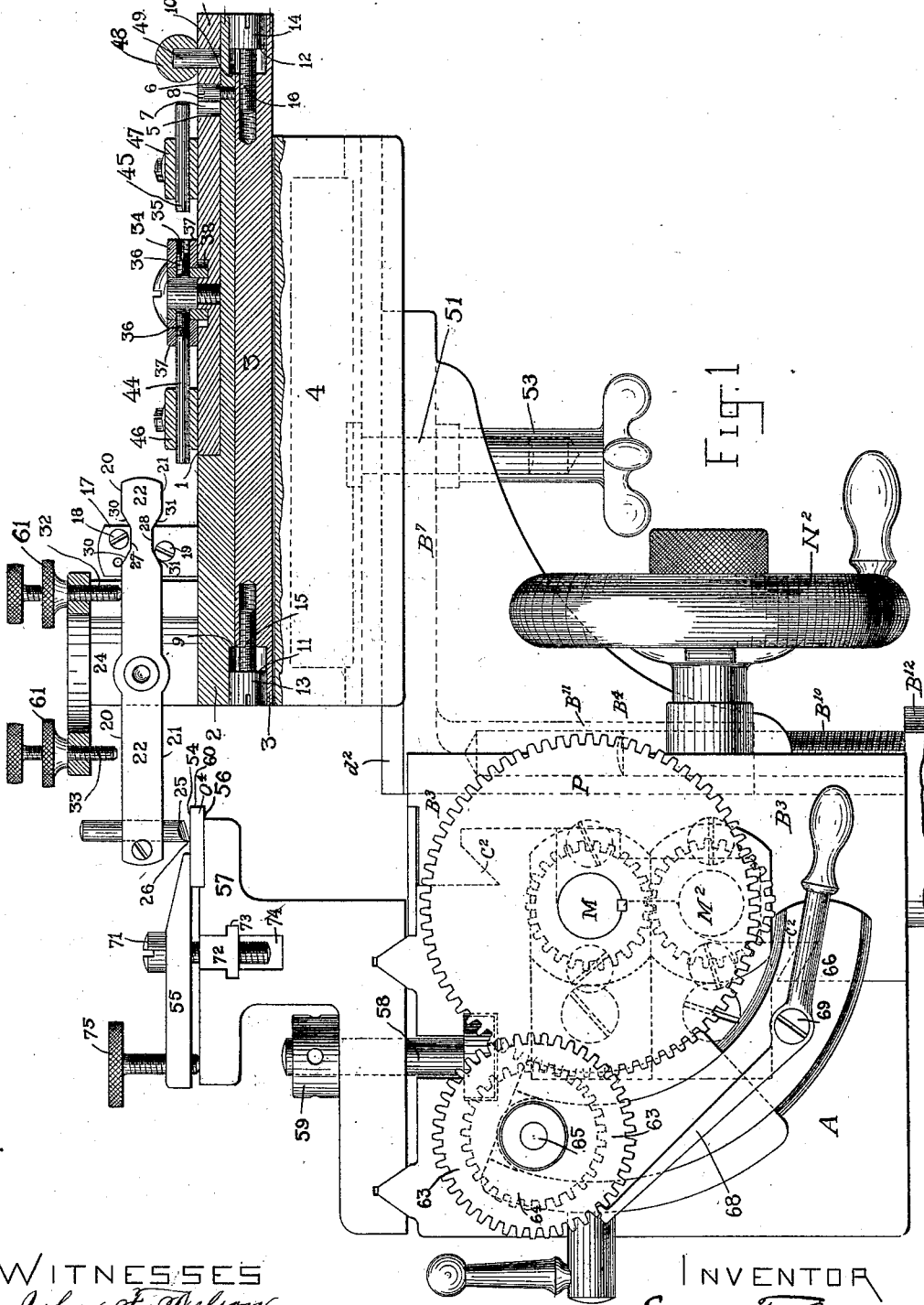

WITNESSES  
*John F. Nelson.*  
*Francis M. Brown.*

INVENTOR  
*George F. Ballou*  
 by his Attys  
*Brown Bros.*

(No Model.)

3 Sheets—Sheet 2.

# G. F. BALLOU. GRADUATING MACHINE.

No. 359,378.

Patented Mar. 15, 1887.

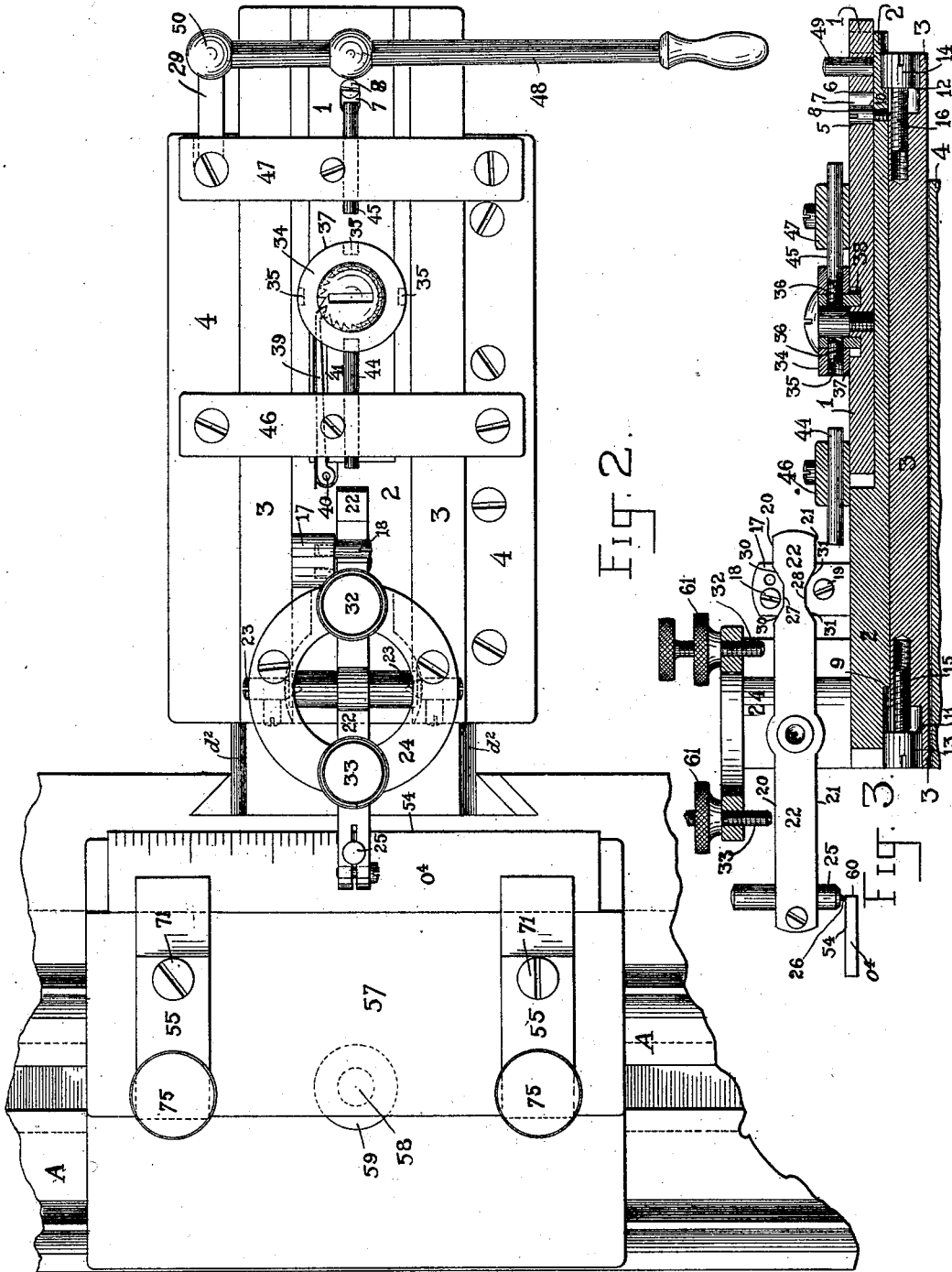

Fig. 2.

WITNESSES  
*John F. Nelson.*  
*Francis M. Brown.*

INVENTOR  
*George F. Ballou*  
 by his Attys  
*Brown Bros.*

(No Model.)

3 Sheets—Sheet 3.

# G. F. BALLOU. GRADUATING MACHINE.

No. 359,378.

Patented Mar. 15, 1887.

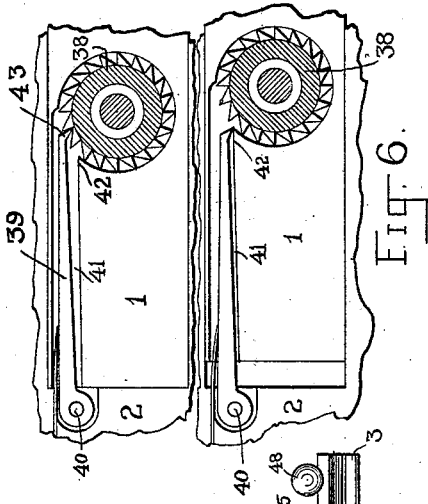

FIG. 6.

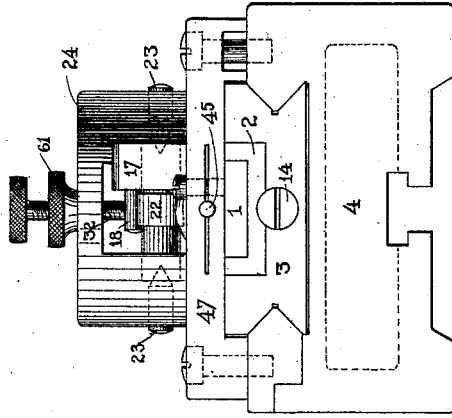

FIG. 5.

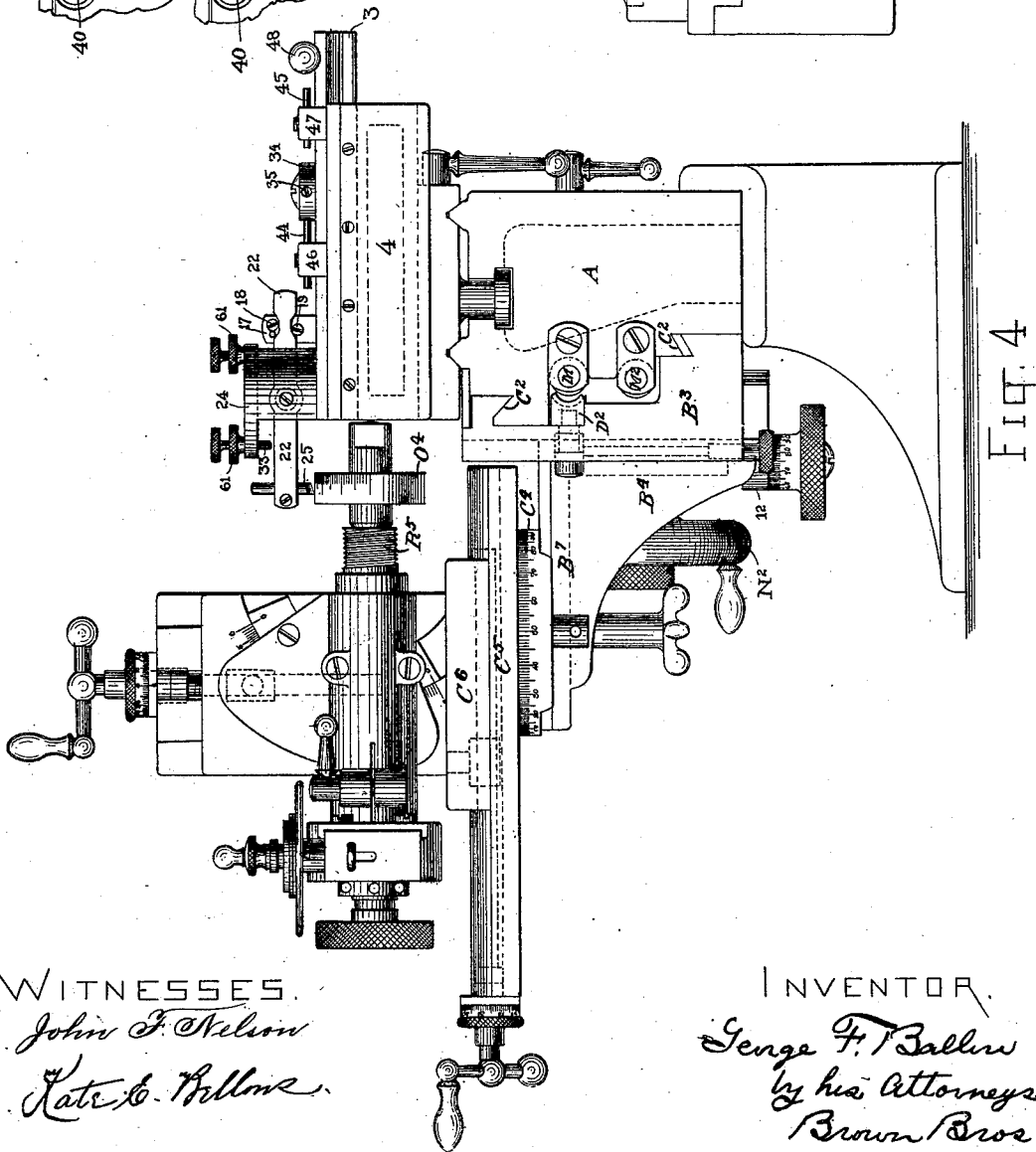

FIG. 4.

WITNESSES.

*John F. Nelson*  
*Kate C. Ballou*

INVENTOR.  
*George F. Ballou*  
by his Attorneys  
*Brown Bros.*

# UNITED STATES PATENT OFFICE.

GEORGE F. BALLOU, OF WALTHAM, MASSACHUSETTS.

## GRADUATING-MACHINE.

SPECIFICATION forming part of Letters Patent No. 359,378, dated March 15, 1887.

Application filed June 9, 1886. Serial No. 204,622. (No model.)

*To all whom it may concern:*

Be it known that I, GEORGE F. BALLOU, of Waltham, in the county of Middlesex and State of Massachusetts, have invented certain new and useful Improvements in Graduating-Machines, of which the following is a full, clear, and exact description.

As well known in graduating, lines are made at regular distances apart, and of lengths regularly increased, to separate the lines into defined groups of equal number for their more convenient reading and designation.

This invention relates to a machine for graduating and, at regular intervals of the series of lines, making them of increased and regular lengths, for the purpose stated.

The machine of this invention is more particularly designed and intended for use with a lathe-bed of the general construction and arrangement, and a slide-carriage and means for moving it horizontally along and adjusting it vertically in relation to a lathe-bed, the same as fully shown and described in a separate application for Letters Patent of the United States, filed June 9, 1886, Serial No. 204,624; but, as will be obvious from the description hereinafter given, the machine of this invention is capable of use with lathe-beds and other supports and slide-carriages of other constructions and arrangements of parts.

This invention in graduating-machines, in substance, consists, first, in combination, two parallel, rectilinear, reciprocating, and superimposed slides and support therefor, a graduating-tool, which is carried by one, and an abutment, which is carried by the other, of said slides and is arranged in one direction only of the movement of said slide to work on and move said tool, and abutments, preferably adjustable, which are on both slides and are arranged in either or both directions of movement of the slide carrying said abutment for working on and moving said tool to join said two slides so as to move together and as one.

It consists, second, in combination, two parallel, rectilinear, reciprocating, and superimposed slides and support therefor, a graduating-tool, which is carried by one, and two abutments, which are carried by the other, of said slides and are arranged one in advance of the other, and one in one direction and the

other in the other direction of movement of said slide, to work on and move said tool, and abutments, preferably adjustable, which are on both slides and are arranged in either or both directions of movement of the slide carrying said abutments for working on and moving said tool to join said two slides so as to move together and as one.

It consists, third, in combination, two parallel, rectilinear, reciprocating, and superimposed slides and support therefor, a graduating-tool, which is carried by one, and two abutments, which are carried by the other, of said slides and are arranged one in advance of the other, and one in one direction and the other in the other direction of movement of said slide, to work on and move said tool, and stops, preferably adjustable, which are on said slide carrying said graduating-tool to the movement in either direction of said tool, and to join said two slides so as to move together and as one.

It consists, fourth, in combination, two parallel, rectilinear, reciprocating, and superimposed slides and support therefor, a graduating-tool, which is carried by one, and an abutment, which is carried by the other, of said slides and is arranged in one direction only of the movement of said slide, to work on and move said tool, abutments, preferably adjustable, which are on both slides and arranged in either or both directions of movement of the slide carrying said abutment, for working on and moving said tool, to join said two slides so as to move together and as one, and a stationary stop or stops, preferably adjustable, and which are arranged to stop the movement in either or both directions of said so-joined slides.

It consists, fifth, in combination, three parallel, rectilinear, reciprocating, and superimposed slides and support therefor, a graduating-tool, which is carried by one, and an abutment, which is carried by another, of said slides and is arranged in one direction only of the movement of said slide, to work on and move said tool, abutments, preferably adjustable, which are carried by said three slides and are arranged in either or both directions of movement of said slide carrying said abutment, to work on and move said tool, to join the three slides so as to move together and as one,

a stationary stop or stops, preferably adjustable, which are arranged to stop the movement in either or both directions of said so-joined slides, a rotatory head which is arranged for the abutment of said stop or stops and is carried by one, and means which are carried by another of said slides, and from the movement of such other slide, in one direction only, to turn said rotatory head.

It consists, sixth, in combination, a graduating-machine of suitable construction, a holder for the work to be graduated by said machine, and means constructed and arranged to present the graduating-machine and work to each other in steps of regular distances or spaces.

In the drawings forming part of this specification, Plate 1, Figure 1 is an end elevation of a lathe-bed having a slide-carriage supported and arranged on its front cheek to be longitudinally and vertically adjusted in relation thereto and of a stand located on and clamped to the lathe-bed and carrying the work to be graduated, and in part a side elevation and longitudinal vertical section of the graduating-machine of this invention, showing it as in operative position for graduating the work secured to the stand on the lathe-bed.

Plate 2: Fig. 2 is a plan view of the parts shown in Fig. 1, with the bed broken away at each end; and Fig. 3 is a central longitudinal vertical sectional view, hereinafter referred to, of the graduating-machine removed from the slide-carriage.

Plate 3: Fig. 4, on a reduced scale, is an end elevation of a slide-lathe having a slide-carriage vertically and horizontally adjustable in relation thereto and of the graduating-machine of this invention, showing it as upon the lathe-bed and in operative position to graduate the edge of the circular disk, carried by an index milling-fixture, which is located upon the slide-carriage and forms the subject of a separate application for Letters Patent, filed June 9, 1886, Serial No. 204,621. Fig. 5 is a view of the machine of this invention, as shown in Figs. 1, 2, detached, and at its front end; and Fig. 6 is an enlarged detail view, as will hereinafter appear.

In the drawings, 1 2 3 are three separate slides, placed horizontally one upon another and severally carried by a common support or casing, 4. Slide 1 is the upper, slide 2 is the middle, and slide 3 is the lower, slide of the series of slides.

5 6 are two abutments, respectively, at the opposite ends of a longitudinal slot, 7, of upper slide, 1, and 8 is a vertical pin on middle slide, 2, and entered into the slot 7 of upper slide, 1.

9 10 are two shoulders or abutments, respectively, at the opposite ends of middle slide, 2, and 11 12 are two stop-screws, respectively, at the opposite end of lower slide, 3. The shoulders or abutments 9 10 of middle slide, 2, and the stop-screws 11 12 of lower slide, 3, are in line with each other, and as to the opposite ends of the two middle and lower

slides, shoulders or abutments 9 and 11 and 10 and 12 in the movements of such slides cooperate, as will hereinafter appear.

17 is a vertical post carried by the middle slide, 2, and 18 and 19 are two horizontal abutment-pins projecting from one side of the post 17 and across, respectively, the upper and lower edges, 20 21, of a horizontal lever, 22, which is suspended at its opposite sides upon horizontal conical bearing-points 23 of a vertical standard or support, 24, attached to lower slide, 3. This lever 22 is the tool-carrier of the machine, and 25 is the tool, which is located and secured in the lever 22 so as, in any suitable manner, to present its cutting edge or point 26 at the under side of the lever.

27 28 are depressions in the upper and lower edges, 20 21, respectively, of the tool-carrying lever 22. These depressions receive the abutment-pins 18 19 of the post 17 of the middle slide, 2, and each depression 27 28, at either end, is made with an incline or cam, 30 31, to secure in the movement of upper and middle slides, 2 3, one upon another, a tilting of the tool-carrying lever 22 by and from the contact of the pins 18 19 upon the inclines of the recesses, and in both directions of the movement of the upper and middle slides, all as will hereinafter more fully appear.

The support 24 for the tool-carrying lever has two adjustable stop screws or pins, 32 33, screwing through the top of the support, and in a line with and so as to have a bearing against the upper edge, 20, of the lever as the lever tilts, and on oppositesides of its fulcrum or bearing conical points 23.

34 is a rotatory vertical head secured to and turning upon slide 1. This head 34 has a series of radial sockets, 35, which, as shown, are four in number, at equal distances around its periphery, and each socket is provided with an adjustable screw-pin, 36, by which to adjust and regulate its depth from the outer periphery or edge, 37, of the head.

38 is a ratchet-wheel of the rotatory head 34, and 39 is a spring-pawl, to engage the teeth of the ratchet-wheel, and which is carried by and swings on a pin, 40, of middle slide, 2, lying in a depression, 41, of upper slide, having an edge, 42, which, in the operation of the machine and as hereinafter appears, supports the pawl 39 and holds its engaging end 43 from contact with the teeth of the ratchet-wheel 38. The rotatory head at its edge or periphery 37, each side of its sockets 35, and the exposed ends or heads of the screw-pins 36, adjustable, as described, act as abutments for two separate and horizontal stop-pins, 44 45, each carried by separate horizontal cross pieces or bars 46 47, crossing the top of the several slides 1 2 3, and at each end and at each side of lower slide, 3, attached to the box or casing 4 of the machine.

The stop-pins 44 45 are in line with each other and with a line coincident with the diametrical line of the rotatory head 34 and the direction of movement of the slides 1 2 3, one

upon another, and of lower slide, 3, on box or casing 4, as will hereinafter appear.

48 is a horizontal handle-lever, through which to operate slides 1 2 3, and connecting mechanism, as will hereinafter appear. This lever 48 is connected to and swings upon a pin, 49, of upper slide, 1, and its fulcrum is at 50 of a link, 29, pivoted on box or casing 4, carrying the several slides.

The machine above described, Figs. 1 and 2, is set by its box 4 upon and secured to a forked horizontal table or arm, B<sup>7</sup>, of an upright, B<sup>4</sup>, together making the bracket and one portion of a slide-carriage of a slide-lathe, consisting in its other and remaining portion, of a vertical plate or block, B<sup>3</sup>, arranged upon and fitting an angular-shaped and vertical guideway, C<sup>2</sup>, of the front cheek of a bed or shears, A—such, for instance, as the bed or shears of a lathe.

In Figs. 1 and 2 the work O<sup>4</sup>, consisting of a flat bar, to be graduated or marked, is secured to the lathe-bed A, as will hereinafter fully appear. Again, the machine, Fig. 4, is set by its box 4 upon and secured to the lathe-bed A, and the work O<sup>4</sup>, consisting of a circular disk, is carried by an arbor or spindle, R<sup>3</sup>, of an index milling-fixture, such as before referred to, and which is attached to the upper slide, C<sup>6</sup>, of the slide-rest, composed of rectilinear and curvilinear moving slides C<sup>4</sup>, C<sup>5</sup>, and C<sup>6</sup>, placed one upon the other, and together secured to the horizontal table B<sup>7</sup> of a bracket, B<sup>4</sup> B<sup>7</sup>, of the slide-carriage, before mentioned.

The bracket portion B<sup>4</sup> B<sup>7</sup> of the slide-carriage is adjustable vertically upon the vertical block or plate B<sup>3</sup>, and together they constitute a slide-carriage constructed and arranged as a whole to be moved longitudinally along the guideway C<sup>2</sup> of the lathe-bed, and for the vertical adjustment of its bracket portion, and for the upper leading-screw, M, as it is turned to work through a half or sectional screw nut or nuts, D<sup>2</sup>, upon the slide-carriage to move it along the bed and the lower leading-screw, M<sup>2</sup>, to secure a similar movement of the slide-carriage by turning a hand-wheel, N<sup>2</sup>, geared to said screw and turning in suitable bearings of the slide carriage. The vertical adjustment of the bracket B<sup>4</sup> B<sup>7</sup> on the slide-carriage is secured by the turning of a vertical screw-rod, B<sup>10</sup>, engaging a vertical screw-nut, B<sup>11</sup>, of the bracket and turning in, but suitably confined against longitudinal movement through, a bearing-block, B<sup>12</sup>, at the lower end of block B<sup>3</sup> of the slide-carriage, and the upright B<sup>4</sup> of the bracket engages a vertical dovetail way of the block B<sup>3</sup>, all, and also as to the slide-rest mentioned, as fully described in said application Serial No. 204,624.

The graduating-machine, Figs. 1, 2, is fastened to the bracket B<sup>4</sup> B<sup>7</sup> of the slide-carriage by a screw-bolt, 51, having its head engaged with a longitudinal T-shaped groove of its box 4 and passing between the tines and to the under side of the forked table B<sup>7</sup>, and there

provided with a tightening screw-nut, 53. Box 4 fits by its flaring edges over the flaring edges of the table-arm B<sup>7</sup> of the slide-carriage. Loosening box 4 from bracket-arm B<sup>7</sup> frees the machine for removal from and movement on the arm B<sup>7</sup> to be adjusted in a rectilinear and horizontal direction and at right angles to the longitudinal axis of the lathe-bed or its arbor; or, in other words, to the lengthwise movement of the slide-carriage with the machine upon the lathe-bed A.

The graduating-machine, Fig. 4, sets upon and is adapted to be moved lengthwise of and fastened to the lathe bed or shears A, and, as usual, with the shoe-plate of a tail-stock and of a T-tool rest to a lathe bed or shears.

Figs. 1 and 2, the work O<sup>4</sup>, a straight bar to be graduated and lined on its surface, is secured with said surface horizontal and uppermost and under and presented toward the cutting-tool 25 by means of adjustable clamp-jaws 55, hereinafter described, on the upper face of a stationary jaw, 56, making a part of a stand, 57, which, as is usual and well known with shoe-plates of T-rests and tail-stocks of slide-lathes, is adapted to be set and to fit upon and to be moved along the length of the lathe-bed and rigidly fastened thereto by a screw-bolt, 58, and screw-nut 59.

The work O<sup>4</sup>, Figs. 1 and 2, secured to a stand, 57, as described and as the same is particularly shown, Fig. 2, has its upper surface, 54, from the edge 60, which is toward the graduating-machine, for a portion of its width and length marked or lined off into a series of spaces of equal width and with the lines running from the edge 60 inward of three different lengths. As shown, the longest line is each and every tenth line of the series of lines, and the shortest each and every line between every tenth line, except the middle line of each group of ten lines, which is the next longest of the series of different lengths of lines, as stated, and of a length between the shortest and longest lengths of lines shown. The production of graduations in lines of varying lengths, as above stated, is one of the principal features aimed at by the present invention, and which is successfully accomplished by the use and operation of the machine described, it being here observed so as to prevent any misunderstanding that the equal spacing between the lines or graduations to be so marked is to be secured either by a proper feed of the work O<sup>4</sup> to the cutting-tool of the machine, which in the arrangement illustrated, Fig. 4, or of the cutting-tool of the machine to the work, which is the arrangement illustrated, Figs. 1 and 2, and in either case with a regular step-by-step movement equal in length to the width of the space desired between the lines or graduations of the work to be produced.

In the machine described the lining or marking is done by the cutting or marking edge 26 of the tool 25, and the tool for such purpose is made to reciprocate over the surface to be marked, running in one direction of its recip-

roca-tion in and in the other direction out of contact with the surface to be cut or marked. The placing of the tool in and out of contact with the bar or work O', as aforesaid, is se-cured by the tilting of lever 22, carrying the tool from the action of the abutments 18 19 of the post 17 thereon in the reciprocating move-ment of the middle slide, 2, on lower slide, 3, and in this reciprocation of the middle slide, 2, the presentation and holding of the tool to the work is secured by the contact of the lower abutment-pin, 19, of middle slide, 2, against the incline 31, at either of the opposite ends of the depression 28 of the lower edge, 21, of lever 22, according as the presentation of the tool to the work is to be made either on the movement of said slide toward or on its move-ment away from the bar or other work O' to be graduated, and the removal of the cutting-tool from the bar is secured in both cases in the opposite movement of middle slide, 2, on lower slide, 3, by the contact of the upper abutment-pin, 18, on the incline 30, at either of the opposite ends of the depression 27 of the upper edge, 20, of the lever 22. The position of the upper abutment-pin, 18, for a working of the tool on the movement of the tool from the edge 60 inward over the bar is back of the position of the lower abutment-pin, 19, and for the working of the tool on the movement of the tool over and toward the front edge, 60, of the bar it is forward of the position of the lower abutment-pin, 19.

In the tilt of the tool-carrying lever 22, as above described, from the reciprocation of middle slide, 2, on lower slide, 3, the adjust-able stop-pins 32 33 act as stops thereto. The stop-pin 32 makes the stop to the tilt of the tilting lever 22 on the movement of middle slide, 2, to carry the tool toward the surface to be graduated by the tool, and the stop-pin 33 makes the stop to the tilt of the tilting lever in the movement of middle slide, 2, to carry the tool out of contact with and away from the surface being graduated. These stop-pins 32 33 are made adjustable as to their action on the lever 22 by entering and screwing them into and through their support 24, and each one adjusted is made fast by a milled head binding or check screw-nut, 61, applied to it. The reciprocation of middle slide, 2, on lower slide, 3, as has been described, is secured through the reciprocation of upper slide, 1, from the swinging of the operating-lever 48, connected therewith, and which, under such reciprocation, abuts by either end, 5 or 6, of its slot 7, according to the direction of move-ment of the slide 1, against pin 8 of middle slide, 2, and which is entered into said slot, and thus, on a continued movement of upper slide, 1, in the same direction, middle slide, 2, is moved and carried along with it, the two then moving together as one. The tilting lever 22 in abutting against either stop-screw 32 33 binds middle slide, 2, to lower slide, 3, and on a then continued swing of the operat-ing-lever the three slides move as one. Dur-

ing the combined movement of the three slides in the one direction the desired marking of the work is accomplished, as will hereinafter more fully appear, and in the other direction, the tool being first lifted from the work, is re-turned to its original position, to be again moved to cut or mark another line, as before, and so on.

Upper slide, 1, in its movement in either direction, carries with it the rotatory head 34 and its ratchet-wheel 38, and the middle slide, 2, in its movement in either direction, carries with it spring-pawl 39. When upper and middle slides, 1 2, are moving together, rota-tory head 34 and its ratchet-wheel 38 and pawl 39 all move as one with said slides. When upper slide, 1, is moving in one direction on middle slide, 2—that is, in a direction toward work O'—the ratchet-wheel 38 moves against pawl 39, and thus the rotatory head is rotated; and when upper slide, 1, is moving in the other direction on middle slide, 2—that is, in a di-rection away from work O'—the ratchet-wheel moves under the pawl, and the head is not ro-tated. This rotation, intermittent of the ro-tatory head 34, places step by step and regu-larly one after another different points of the edge or periphery 37, including the radial sockets 35, of the head in the line of and oppo-site to the ends of the horizontal stop-pins 44 45, to act in each instance in the continued and combined movement of slides 1 2 3 in a direc-tion toward the edge of the work being gradu-ated as an abutment against the presented end of the stationary stop pin 44, and in the com-bined movement of the slides from the edge of the work being graduated as an abutment against the presented end of the stationary stop-pin 45.

The contact between a stationary stop-pin 44 45 and the rotatory head 34, as described, arrests and stops the further movement of slides 1, 2, and 3 in the direction of their then movement, and, as is plain, for all abutting-points of the rotatory head between the radial sockets 35 of the head; or, in other words, for all points at equal distances from the axis of the head slides 1, 2, and 3 will be stopped on a completion of the same length of movement and for all abutting-points of the rotatory head inside of the periphery 37 of the head—as, for instance, at the inner ends of the radial sockets 35 of the head—slides 1, 2, and 3 will be allowed a length of movement in each in-stance greater than their length of movement when stopped by contact between a stop-pin 44 or 45 and the periphery 37 of the head. As is obvious, by adjusting the depths of the radial sockets 35, the movement of the slides may be made of equal or unequal lengths as to each other. From this difference in the length of the movement of slides 1, 2, and 3, insured by the contact between a stop-pin 44 45 and the rotatory head 34, differences in the length of the graduating-lines made by the tool are secured, all of which in the present instance, and as the same is illustrated, is such

as to allow, on the completion of each and every successive ten steps of the step-by-step rotation of the head, the greatest and an equal length in each case of movement of slides 1, 2, and 3 in the direction in which the tool is arranged to work, and again as to allow, on the completion of each and every fifth step, the next greatest and an equal length in each case of movement of slides, 1, 2, and 3 in the direction in which the tool is arranged to work; and, further, as to allow on the completion of each and every one of the remaining step-by-step movements of the head, and between each and every tenth and fifth steps thereof, as above stated, the shortest and an equal length of movement in each case of slides 1, 2, and 3 in the direction in which the tool is arranged to work. The arrest or stop of the movement of slides 1, 2, and 3 for each and all the shortest lengths of movement above stated is from the contact between a stationary stop-pin 44 or 45 and the outer edge or periphery, 37, of the rotatory head 34, lying between its radial sockets 35, and for each and all of the next longest and the longest lengths of movement of slides 1, 2, and 3 said arrest or stop thereof is from the contact between a stationary stop-pin 44 or 45 and the inner end of a radial socket 35 of the rotatory head 34, in each instance suitably adjusted therefor.

From a relative operation, such as above described, between a rotatory head, 34, and a stop-pin of the stop-pins 44 45, and which may be either one or the other of said pins, according as the machine is adjusted to work in the reciprocation of the tool in either the one or the other of its directions of movement, as has been described, obviously graduating lines of varying lengths, running from and at right angles to a given and common base-line, will be produced by the tool, and as the rotatory head and stop-pins are particularly shown and described, (it being understood that either the graduating apparatus or the work is properly and regularly fed step by step in relation to each other for the spacing desired between the lines,) each and every tenth line will be a line of the greatest but of equal length, each and every middle line between said tenth lines a line of the next greatest but of equal length, and each and every other line of the series of lines making such a group of lines of the smallest but of equal length, and all practically as shown in the drawings, Fig. 2, as on the surface of a straight bar, and in the other case, Fig. 4, as on the circular edge of a disk, each marked O<sup>4</sup>.

In a machine such as above described obviously the relative lengths of the lines of graduations produced by it, as above stated, and which make up a given number of lines in a given group of lines, may be varied by a suitable relative adjustment of the abutting-points of the rotatory head 34 for a stop-pin 44 45, and, again, the number of variations in length of the separate lines in the group of lines given

and stated may be increased or decreased by increasing or decreasing the number of radial sockets 35 of rotatory head 34.

Again, in a machine such as described the separate step-by-step movement of the rotatory head from the action of the pawl 39 of middle slide, 2, on the ratchet-teeth 38 of the rotatory head, caused by the movement of said slide 2 independent and separate from upper slide, 1, obviously may be changed—that is, made either of a greater or less proportion of the whole rotation of the head—by a suitable relative construction of ratchet-wheel and operation of pawl therewith, as well known. Again, the lines of graduation may be run for a greater or less width of the surface to be graduated by arranging slides 1, 2, and 3 to have, after the tool has been presented for work, a greater or less length of movement across the surface to be graduated.

As the graduating-machine of this invention is illustrated, Figs. 1, 2, and 4, the tool operates on the work in its movement from the edge of the work toward the work-clamping stand, Figs. 1 and 2, and toward the index milling-fixture, Fig. 4. Again, as the machine is illustrated, Fig. 3, the tool operates on the work in its movement in the opposite direction to that in which it operates as illustrated, Figs. 1, 2, and 4.

In either direction of movement of the middle slide, 2, on lower slide, 3, if the contact between the two is made through means of the stop-screws 11 12, the stop-pins 32 33 for the tilting lever 22 may be dispensed with; but it is preferable to use them, and for both directions of movement of middle slide, 2, on lower slide, 3, for the reason that in the direction of movement of the slides in which the tool is working the stop-pin 32 holds the tool rigidly to its work, regulating the depth of its cut, and in the other and opposite direction of movement of the slides, and in which direction the tool is being returned to its normal position, the stop-pin 33 holds the lever 22 for the better presentation of the depression 28 to the contact of the lower abutment-pin, 19, in the next movement of said slide in the direction for producing another line.

Upper slide, 1, in its movement on and separate from middle slide, 2, is allowed a length of movement in excess of that required for the turning of the rotatory head 34, as has been described, for the purpose of enabling the rotatory head to be withdrawn from engagement with the stop-pin 44 or 45, as the case may be, before and preparatory to the head being rotated by the conjoined operation of the ratchet of said head and the pawl. To insure, with this excess of separate movement of upper slide, 1, on middle slide, 2, the proper presentation of the pawl to the ratchet of rotatory head 34 for the required rotation of said head, an edge, 42, of the middle slide, 2, is provided for the rest and support of the pawl away from the teeth of the ratchet for the length in both directions of this excess of

travel of upper slide, 1, on middle slide, 2, as above stated.

In the use of the graduating-machine of this invention, with the same supported on a slide-carriage, B' B', of a lathe-bed, A, having leading-screws M M' for moving it lengthwise on bed A, and the work O' to be graduated clamped to a stand, 57, secured on the lathe-bed, the machine and work are first adjusted longitudinally, horizontally, and vertically in proper relation to each other. So adjusted, the graduating-machine is then moved from time to time step by step along the lathe-bed, and after each step-by-step movement, and with the machine then at rest, the machine is operated through its operating handle 48 to graduate the work O' by the tool 25, and the tool returned to its normal position for the next step-by-step movement of the machine along the lathe-bed, after which, with the machine again at rest, another line of graduation is made on the work O', as before, and so on.

The step-by-step movement of the graduating-machine along the lathe-bed, as above stated, is secured through the rotation of the leading-screw M, operated from the turning of an index-wheel, 63, having a gear-wheel, 64, meshing a gear-wheel, P, of said leading-screw. The index-wheel 63 and its gear-wheel 64 turn as one on a stud, 65, attached to a curvilinear bar, 66, which is located and fits in a corresponding curvilinear dovetail way or groove of the end of the lathe-bed, and is suitably adapted to be made rigid and fast in its curvilinear way, and preferably in a manner to be capable of being readily loosened for being moved along the length of said way, for a purpose which hereinafter appears.

The curvilinear bar 66 and its guideway are concentric with the axis of rotation of the leading-screw M, and the bar has a pawl, 68, swinging upon a pin, 69, and arranged to engage and maintain, except when released by the hand, engagement with a tooth of the series of equidistant teeth around the edge of the index-wheel 63. With the pawl 68 engaged with the teeth of the index-wheel and the bar 66 loosened so as to be free to be moved lengthwise in its guideway on a then movement of the bar in one direction along its guideway, the index-wheel and its gear-wheel 64, meshing gear-wheel P of leading-screw, and said gear-wheel P and leading-screw will all turn as one about the axis of the leading-screw, and thus through it move the slide-carriage B' B' and graduating-machine along the lathe-bed. In this manner the marking end of the tool of the graduating-machine may be placed at any desired position within certain limits in relation to the work to be graduated, without requiring the position of index-wheel relative to the leading-screw to be changed and irrespective of the divisions of the index-wheel, and whether or not the position to which the working edge or point of the tool has been so brought was a position coincident with the unit of the divisions of the in-

dex-wheel, as represented by the teeth in its edge, and which teeth are to be used as the index in spacing the lines of graduations to be produced by the operation of the graduating-machine of this invention in the combination of Figs. 1 and 2.

The number of separate teeth in index-wheel 63 and the number of separate turns of the wheel necessary to move the graduating-machine through a given length of the work O', Figs. 1 and 2, to be graduated determine the greatest or total number of separate equidistant graduations, and also all numbers which are less than said total number into which said given lengths of the work O' can be graduated by the machine.

In lieu of attaching the graduating-machine to the slide-carriage B' B' and the work-stand 57 to the lathe-bed, as described and shown, Figs. 1, 2, and 4, the graduating-machine may be secured to the lathe-bed and the work-clamp secured to the slide-carriage, each suitably constructed therefor. With the parts so changed in position and properly adjusted, the work O' will then be moved along by the operation described of the index-wheel, in lieu of the graduating-machine.

The spacing of the work O', Fig. 4, is from the operation of an index milling fixture, making the subject of an application for Letters Patent before referred to, Serial No. 204,621, and to which reference is hereby had for a particular description of it.

Cutting or marking tools of various kinds may be used, and, if a diamond, as is often the case, or such other as in operation either of itself or from the nature of the work it is best to work with only the gravity of the tool-holder for its pressure, then the stop-pin 32 or 33, as the case may be, for the tilting lever 22 on its tilt to place the tool in operative position on the work is removed from the abutment on the lever and the connecting of middle slide, 2, with lower slide, 3, for carrying the tool over the work in both directions, is made by the contact of the stop-screws 11 12 of lower slide, 3, with middle slide, 2. Again, in such cases it is best that the machine should be arranged for the tool to work in being drawn over the surface—as, for instance, to work as it moves from a point within the outer edge, 60, of the work O' toward said outer edge.

If so desired, both stop-pins 44 45 to the rotatory head may be used for arresting the rectilinear movement in both directions of slides 1, 2, and 3; but this is only necessary when the lines of graduations are to be made and projected each side of a line common and central between and parallel with a line drawn through the points of termination of the separate lines of graduation at each side of said central line.

71 is a headed screw-bolt, passing loosely through thickness of clamp-jaw 55 and screwing into screw-nut 72, of T shape, and fitting the upper and T-shaped portion of a vertical

groove, 73, in stand 57 for the work O<sup>4</sup>, Fig. 1. The groove 73 has a downward extension, 74, below the screw-nut 72, for the screw-bolt 71 to be projected into it, and thus to accommodate the clamp-jaw for varying thicknesses of work O<sup>4</sup>, and so that at all times in practical use the screw-bolt 71 will be entered into the screw-nut and have a hold therein of some and a sufficient length to insure the rigid clamping of the work.

Each clamp-jaw 55 has an adjustable abutting-screw, 75, at its tail end, the better to adjust its gripping end to its work, and each is adjustable lengthwise of the stand, moving its T-shaped screw-nut along the groove of the stand, first having loosened the screw-bolt and nut sufficiently therefor.

Having thus described my invention, what I claim, and desire to secure by Letters Patent, is—

1. In a graduating-machine, in combination, two parallel, rectilinear, reciprocating, and superimposed slides and support therefor, a graduating-tool carried by one and an abutment carried by the other of said slides and arranged, in one direction only of the movement of the slide, to work and move said tool, substantially as described, for the purpose specified.

2. In a graduating machine, in combination, two parallel, rectilinear, reciprocating, and superimposed slides and support therefor, a graduating tool carried by one and two abutments carried by the other of said slides and arranged to work on and move said tool, substantially as described, for the purpose specified.

3. In a graduating-machine, in combination, two parallel, rectilinear, reciprocating, and superimposed slides and support therefor, a graduating-tool carried by one and an abutment carried by the other of said slides and arranged, in one direction only of the movement of the slide, to work on and move said tool, and a stop to the movement of said tool, substantially as described, for the purpose specified.

4. In a graduating-machine, in combination, two parallel, rectilinear, reciprocating, and superimposed slides and support therefor, a graduating-tool carried by one and two abutments carried by the other of said slides and arranged to work and move said tool, and stops to the movement of said tool, substantially as described, for the purpose specified.

5. In a graduating-machine, in combination, two parallel, rectilinear, reciprocating, and superimposed slides and support therefor, and said slides constructed and arranged to move separately and together, a graduating-tool carried by one and an abutment carried by the other of said slides and arranged, in one direction only of the movement of the slide, to work on and move said tool, substantially as described, for the purpose specified.

6. In a graduating-machine, in combination, two parallel, rectilinear, reciprocating, and

superimposed slides and support therefor, and said slides constructed and arranged to move separately and together, a rotatory abutment-head on one and a pawl on the other of said slides to operate said head, and a stationary stop to the movement of the slides, combined substantially as described, for the purpose specified.

7. In a graduating-machine, three parallel, rectilinear, reciprocating, and superimposed slides and support therefor, and said slides constructed and arranged for movement separately and together, a graduating-tool carried by one and an abutment carried by another of said slides and arranged, in one direction only of the movement of the slides, to work on and move said tool, substantially as described, for the purpose specified.

8. In a graduating machine, three parallel, rectilinear, reciprocating, and superimposed slides and support therefor, and said slides constructed and arranged for movement separately and together, a graduating-tool carried by one and an abutment carried by another of said slides and arranged, in one direction only of the movement of the slides, to work and move said tool, a rotatory abutment-head on one and a pawl on another of said slides to operate said head, and a stationary stop to the movement of the slides, combined substantially as and for the purpose specified.

9. In a graduating-machine, in combination, three parallel, rectilinear, reciprocating, and superimposed slides and support therefor, and said slides constructed and arranged for movement separately and together, a graduating-tool carried by one and an abutment carried by another of said slides and arranged, in one direction only of the movement of the slides, to work on and move said tool, a stop to the movement of said tool, a rotatory abutment-head on one and a pawl on another of said slides to operate said head, and a stationary stop to the movement of the slides, combined substantially as described, for the purpose specified.

10. In a graduating-machine, in combination, parallel, rectilinear, reciprocating, and superimposed slides and support therefor, a graduating-tool carried by one and an abutment or abutments carried by another of said slides and arranged to work on and move said tool, a rotatory abutment-head on one and a pawl on another of said slides to operate said head, and a stationary stop to the movement of the slides, combined substantially as described, for the purpose specified.

11. In a graduating-machine, in combination, parallel, rectilinear, reciprocating, and superimposed slides and support therefor, a graduating-tool carried by one and an abutment or abutments carried by another of said slides and arranged to work on and move said tool, a rotatory abutment-head on one and a pawl on another of said slides to operate said head, and a stationary stop to the movement in opposite directions of the slides, com-

bined substantially as described, for the purpose specified.

12. In combination, a graduating-machine of suitable construction, a support in two parts, one for said machine and the other for the work to be graduated, a bed or shears to receive one part of said support and whereon it is free to be moved lengthwise, and means to engage the so-moving part of said support and suitably operated to move it along the bed or shears, substantially as described, for the purpose specified.

13. In combination, a graduating-machine of suitable construction, a support in two parts, one for said machine and the other for the work to be graduated, a bed or shears to receive one part of said support and whereon it is free to be moved lengthwise, and mechanism consisting of a horizontal rotating leading-screw carrying said so-moving part of the support, and an index mechanism connected to and to operate said leading-screw, substantially as described, for the purpose specified.

14. In a graduating-machine, in combination, parallel rectilinear reciprocating superimposed slides and a suitable support therefor, a graduating-tool carried by one, a rotatory head carried by another, and a pawl carried by another of said slides, abutments of said slides, for joining the slides one to another and, in one direction only of movement of the slides, to operate said head, a rest to hold in the opposite direction of movement of the slides said pawl from operation on said head, and a stationary stop for contact of said head and to limit the movement of slides, substantially as described, for the purpose specified.

15. In a graduating-machine, in combination, parallel rectilinear reciprocating superimposed upper, middle, and lower slides, 1 2 3, and support 4, suitable therefor, abutments 5 6 at opposite points of upper slide, 1, abutment-pin 8 on middle slide, 2, for abutments 5 6 of upper slide, 1, a lever, 22, on lower slide, 3, and carrying graduating-tool, and stops or abutments 9 and 11 and 10 and 12 between slides 2 3 to join the two, substantially as described, for the purpose specified.

16. In a graduating-machine, in combination, parallel rectilinear reciprocating superimposed upper, middle, and lower slides, 1 2

3, and support 4 therefor, an abutment-pin, 8, on middle slide, 2, abutments 5 6 on upper slide, 1, for abutment-pin 8, a lever, 22, on lower slide, 3, and carrying graduating-tool, abutments 18 19 of middle slide, 2, for lever 22, stops 32 33 for lever 22, and carried by lower slide, 3, substantially as described, for the purpose specified.

17. In a graduating-machine, in combination, parallel rectilinear reciprocating superimposed upper, middle, and lower slides, 1 2 3, and support 4 therefor, abutments 5 6 at opposite ends of upper slide, 1, a lever, 22, on lower slide, 3, and carrying graduating-tool, an abutment, 19, for lever 22 on middle slide, 2, stops or abutments 9 and 11 and 10 and 12 between slides 2 and 3, a rotatory head, 34, on upper slide, 1, and a pawl, 39, on middle slide, 2, to operate on said head 34, substantially as described, for the purpose specified.

18. In combination, a graduating-machine of suitable construction, a support for the work to be graduated, which is composed of a stand, 57, making one jaw of a clamp to clamp the work, and of an opposite jaw or jaws, 55, secured by headed screw-bolt 71, passing loosely through jaw 55 and screwing into a screw-nut, 72, fitting and engaging a way, 73, of said stand, and provided with an extension, 74, for projection of screw-bolt through said screw-nut, substantially as described, for the purpose specified.

19. In combination, a graduating-machine of suitable construction, a support for the work to be graduated, and means to space the graduations, consisting of a bed or shears, a carriage to move lengthwise of said bed, a rotating leading-screw, M, connected to said carriage to so move it, an index-wheel, 63, geared with said leading screw and carried by a curvilinear sliding bar, 66, and a pawl, 68, on said bar, to be engaged with and disengaged from said index-wheel, substantially as described, for the purpose specified.

In testimony whereof I have hereunto set my hand in the presence of two subscribing witnesses.

GEO. F. BALLOU.

Witnesses:

ALBERT W. BROWN,  
FRANCES M. BROWN.